

MODEL L070

Installation and Operating Manual

**SIDE MOUNTED
LIQUID LEVEL
FLOAT SWITCH
FOR INDUSTRIAL
USE**



Innovative Solutions

60 Great Hill Road
ph: 203-729-6434

Naugatuck, CT 06770
fax: 203-729-6696

www.innovativesensing.com

Read this Manual Before Installing

This manual provides information on the L070 Float Level Switch. It is important that all instructions are read carefully and followed in sequence. Detailed installation and wiring instructions are included in this manual.

Conventions Used in this Manual

Certain conventions are used in this manual to convey specific types of information. General technical material, support data, and safety information are presented in narrative form. The following styles are used for notes, cautions, and warnings.

NOTES

Notes contain information that augments or clarifies an operating step. Notes do not normally contain actions. They follow the procedural steps to which they refer.

Cautions

Cautions alert the technician to special conditions that could injure personnel, damage equipment, or reduce a component's mechanical integrity. Cautions are also used to alert the technician to unsafe practices or the need for special protective equipment or specific materials. In this manual, a caution box indicates a potentially hazardous situation which, if not avoided, may result in minor or moderate injury.

WARNINGS

Warnings identify potentially dangerous situations or serious hazards. In this manual, a warning indicates an imminently hazardous situation which, if not avoided, could result in serious injury or death.

Safety Messages

Follow all standard industry procedures for servicing electrical equipment when working with or around high voltage. Always shut off the power supply before touching any components.

WARNING! Explosion hazard. Do not connect or disconnect equipment unless power has been switched off or the area is known to be non-hazardous.

Low Voltage Directive

For use in Installation Category II, Pollution Degree 2. If equipment is used in a manner not specified by the manufacturer, protection provided by the equipment may be impaired.

Notice of Trademark, Copyright, and Limitations

Copyright © 2009 Solutions With Innovation LLC; D.B.A. Innovative Solutions
All rights reserved.

Performance specifications are effective with date of issue and are subject to change without notice. Innovative Solutions reserves the right to make changes to the product described in this manual at any time without notice. Innovative Solutions makes no warranty with respect to the accuracy of the information in this manual.

Warranty

All Innovative Solutions mechanical level and flow controls are warranted free of defects in materials or workmanship for two full years from the date of original factory shipment.

If returned within the warranty period; and, upon factory inspection of the control, the cause of the claim is determined to be covered under the warranty; then, Innovative Solutions will repair or replace the control at no cost to the purchaser (or owner) other than transportation.

Innovative Solutions shall not be liable for misapplication, labor claims, direct or consequential damage or expense arising from the installation or use of equipment. There are no other warranties expressed or implied, except special written warranties covering some Innovative Solutions products.

Quality Assurance

The quality assurance system in place at Innovative Solutions guarantees the highest level of quality throughout the company. We are committed to providing full customer satisfaction both in quality products and quality service.

MODEL L070

SIDE MOUNTED LIQUID LEVEL FLOAT SWITCH

Table of Contents

1.0 Installation

1.1 Unpacking	1
1.2 Before You Begin	1
1.2.1 Site Preparation.....	1
1.2.2 Equipment and Tools	1
1.3 Mounting.....	2
1.3.1 Threaded Mounting.....	2
1.3.2 Flanged Mounting	2
1.4 Wiring	2

2.0 Preventative Maintenance

2.1 What to do.....	3
2.1.1 Keep Control Clean	3
2.1.2 Inspect Connections Monthly	3
2.1.3 Inspect Entire Model L070 Unit Periodically	3
2.2 What to Avoid.....	3

3.0 Reference Information

3.1 Description	4
3.2 Theory of Operation	4
3.3 Troubleshooting.....	4
3.3.1 External Causes	4
3.3.2 Model L070 Causes.....	5
3.4 Agency Approvals.....	6
3.5 Specifications	7
3.5.1 Physical Specifications.....	7
3.5.2 Electrical Specifications.....	7
3.5.3 Dimensional Specifications.....	8
3.6 Model Numbers	9

1.0 Installation

This section provides detailed procedures for properly installing the Model L070 Liquid Level Switch.

Caution: If equipment is used in a manner not specified by manufacturer, protection provided by equipment may be impaired.

1.1 Unpacking

Unpack the instrument carefully. Inspect all units for damage. Report any concealed damage to the carrier within 24 hours. Ensure that all components have been removed from the packing material. Check all contents against the packing list and report any discrepancies to the factory. Check the nameplate model number to ensure that it corresponds with the packing slip and purchase order. Record the serial and model numbers for future reference when ordering parts.

Model Number _____

Serial Number _____

1.2 Before You Begin

Caution: During the installation of Model L070, the float and pivot area must be kept free of metallic particles that might be attracted to the magnet.

Caution: This instrument is intended for use in Installation Category II, Pollution Degree 2.

1.2.1 Site Preparation

1. Ensure that the length and the inside diameter of the mounting nozzle are sized correctly for the Model L070. See dimensional information on page 8 for requirements.
2. Ensure that the mounting nozzle, coupling or flange is within 3° of horizontal. If mounting the L070 in an external cage, ensure that the top/bottom piping is within 3° of vertical in all directions.

1.2.2 Equipment and Tools

No special equipment or tools are required to install the Model L070 Liquid Level Switch. The following items are recommended:

- Wrenches, gaskets and/or bolting as appropriate for the process connection.
- Pipe wrench
- Level

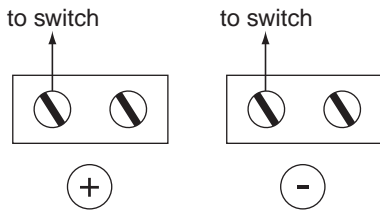

Figure 1
SPST wiring diagram

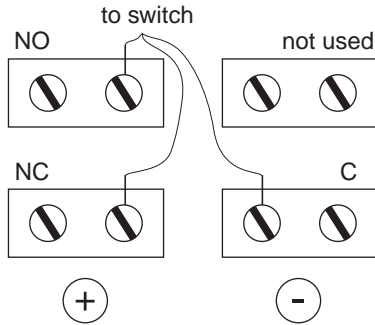

Figure 2
SPDT wiring diagram

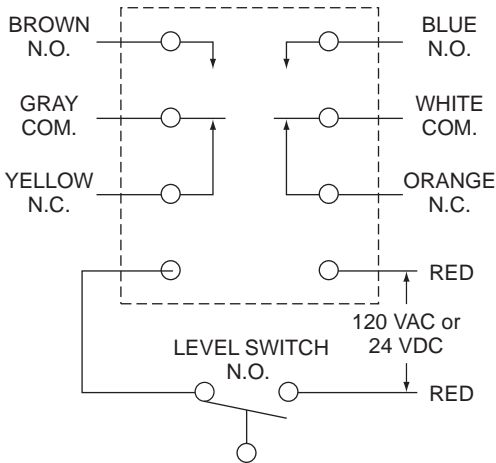

Figure 3
DPDT wiring diagram

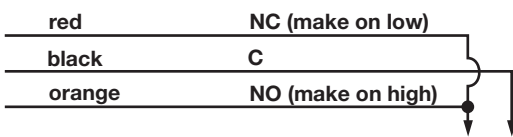

Figure 4
SPDT Flying leads wiring diagram

1.3 Mounting

The Model L070 Liquid Level Switch is available with a 1½" or 2" threaded mounting bushing as well as several flange mountings.

1.3.1 Threaded Mounting

Apply either Teflon® tape or appropriate lubricant to mounting threads to prevent galling. Engage thread by hand to avoid damage. Using a pipe wrench, rotate the unit clockwise until threads are tight in mounting. Ensure that the N.O. marking on body is upward for normally opened operation on models with SPST switches. For normally closed operation, ensure that the N.C. marking is upward. Models with SPDT or DPDT switches should be mounted with the N.O. marking upward.

1.3.2 Flanged Mounting

Have proper flange bolting and gasket(s) on hand. Carefully align the bolt holes of the L070 flange with those of the vessel mounting flange. Ensure that the N.O. marking on body is upward for normally opened operation on models with SPST switches. For normally closed operation, ensure that the N.C. marking is upward. Models with SPDT or DPDT switches should be mounted with the N.O. marking upward. Ensure that the flange gasket is seated properly. Install flange bolting.

1.4 Wiring

NOTE: A switch or circuit breaker shall be installed in close proximity to equipment and within easy reach of operator. It shall be marked as the disconnecting device for the equipment.

NOTE: For supply connections in installations with ambient temperature up to +70° C, use wire with a minimum rating of 75° C as required by the process conditions. Installations with ambient temperatures up to +80° C require wire with a minimum rating of 85° C as required by the process conditions. Use a minimum of 14 AWG wire for power and ground field wires.

1. SPST reed switch: Connect wiring to red switch leads or terminals per wiring diagram. See figure 1.
2. SPDT reed switch: Connect wiring to proper switch leads or terminals per wiring diagram. See figures 2 and/or 4.
3. DPDT relay: Connect wiring to proper terminals by color and run power supply according to the wiring diagram. See figure 3. This relay must be powered to function. 5A @ 24 VDC relay requires 24 VDC power supply while the 5A @ 120 VAC relay requires 120 VAC power supply.

NOTE: Observe all applicable electrical codes and proper wiring procedures.

2.0 Preventive Maintenance

Periodic inspections are a necessary means to keep your level control in good working order. This control is a safety device that protects the valuable equipment it serves. A systematic program of preventive maintenance should be implemented when the control is placed into service. If the following instructions are observed, your control will provide reliable protection of your equipment for many years.

2.1 What to Do

2.1.1 Keep Control Clean

If applicable, be sure the switch housing cover is always in place. This cover protects against damaging moisture and acts as a safety feature by keeping bare wires and terminals from being exposed. Should the housing cover become damaged or misplaced, obtain a replacement immediately.

2.1.2 Inspect Connections Monthly

L070 level switches may sometimes be exposed to excessive heat or moisture. Under such conditions insulation on electrical wires may become brittle, eventually breaking or peeling away. The resulting bare wires can cause short circuits. Check wiring carefully and replace at first sign of brittle insulation.

Check all electrical connections to ensure that they are tight. Check wiring carefully and repair or replace if necessary.

2.1.3 Inspect Entire Model L070 Unit Periodically

A periodic cleaning of the float, pivot and magnet assembly will ensure continued free movement of the mechanism.

2.2 What to Avoid

1. NEVER leave the switch housing cover off of the control longer than is necessary to make routine inspections.
2. NEVER place a jumper wire across terminals to “cut-out” the control. If a jumper is necessary for test purposes, ensure that it is removed before placing the control into service.
3. NEVER use in systems containing iron particles. The magnet in the float assembly can attract the particles and become jammed.
4. NEVER put insulation over the switch housing.

3.0 Reference Information

This section presents an overview of the operation of the Model L070 Liquid Level Switches, including information on troubleshooting common problems, maintenance procedures, listings of agency approvals, and detailed physical, functional, and performance specifications.

3.1 Description

The Model L070 Liquid Level Switches are float actuated devices designed for horizontal mounting in a tank or process vessel through threaded or flanged connections. This low cost switch is ideal for OEM applications where a single point high or low level alarm is desired.

3.2 Theory of Operation

Switching action is achieved through the use of a magnet attached to the float assembly and its interaction with a switch mechanism. Separating the float magnet and the switch is a non-magnetic pressure barrier.

As the liquid level changes, the float along with the float magnet moves. The magnetic field of the float magnet causes a change of state of the switch, making or breaking an electrical circuit.

3.3 Troubleshooting

The Model L070 Liquid Level Switch is designed and engineered for trouble-free operation. Common problems are discussed in terms of their symptoms and corrective actions as recommended.

3.3.1 External Causes

Usually the first indication of improper operation is failure of the controlled equipment to function (e.g., pump will not start (or stop), signal lamps fail to light, etc). When these symptoms occur, whether at the time of installation or during routine service thereafter, check for the following potential external causes first:

- Blown fuses
- Tripped reset button(s)
- Open power switch
- Faulty equipment controlled by level switch
- Defective wiring to level switch

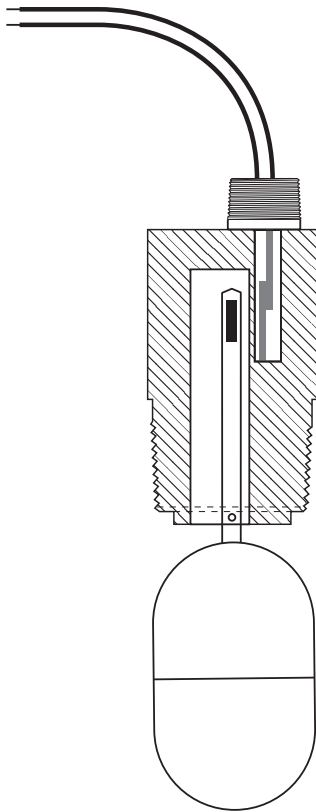

Figure 5
Cross section

3.3.2 Model L070 Causes



If a thorough inspection of these possible conditions fails to locate the cause of the problem, proceed to a check of the Model L070's switch mechanism.

1. Disconnect power to the level switch.
2. Use an electrical continuity checker to determine if the switch is electrically functional. If the switch does not operate properly when electrically activated, the entire level switch must be replaced.
3. If the unit is equipped with a DPDT relay, ensure that it is properly powered (24 VDC or 120 VAC depending upon model). Relay will not function unless it is powered.
4. If the switch functions properly electrically but does not activate when the float changes position, remove level switch from service. Check the float assembly for obstructions or accumulation of particles which may cause binding. If binding is present in the float assembly and cannot be cleared by normal cleaning procedures, the entire control must be replaced.
5. If the complete Model L070 level switch operates properly when removed from service, check to ensure that liquid is entering the tank or vessel. A closed valve or clogged pipeline may prevent movement of the liquid in the vessel.
6. Check the float to make sure it is buoyant in the liquid (tank or vessel must have adequate level).
7. If the float is determined to be filled with liquid or is collapsed, the entire level switch must be replaced. Do not attempt to repair the float.

If all of the components of the level switch are in operating condition, the trouble is likely located external to the level switch. Repeat inspection of external conditions as described in Section 3.3.1.

NOTE: When in doubt about the condition or performance of a Model L070 control, consult the factory for further instructions.

3.4 Agency Approvals

AGENCY	APPROVED MODEL	PROTECTION METHOD	AREA CLASSIFICATION
FM 	L070-BBCC-DDEE	Explosion Proof	Class I, Div 1; Groups C, D
	L070ABBCC-DDEE		Class II, Div 1; Groups E, F, G Class III, Type 4, T6
			No Electrical Enclosure Class I, Div 1; Groups A,B,C,D
CSA 	L070-BBCC-DDEE	Explosion Proof	Class I, Div 1; Groups C, D
	L070ABBCC-DDEE		Class II, Div 1; Groups E, F, G Class III, Type 4, T6
			No Electrical Enclosure Class I, Div 1; Groups A,B,C,D

3.5 Specifications

3.5.1 Physical Specifications

Measured Variable	Liquid level
Physical Range	Narrow differential, 0.50"
Minimum Specific Gravity	0.40
Float Material	316/316L stainless steel
Mounting Connection Material	316/316L stainless steel
Trim Material	316/316L with 18-8 stainless steel pivot pin
Process Connections	1½" or 2" NPT or BSP threads 2", 2-1/2", 3", 4" (150# or 300# ANSI flanges)
Process Temperature Range	-40° to +300° F (-40° to +149° C)
Ambient Temperature Range	-40° to +160° F (-40° to +71° C)
Maximum Process Pressure	1500 psi (103 bar) threaded mount, derated to flange limits

3.5.2 Electrical Specifications

Signal Output	Switch closure
Type of Contacts	SPST, SPDT or DPDT
Type of Switches	Hermetically sealed reed switch DPDT Relay (CL.1, Div.2)
Switch Ratings	SPST 100 VA, 240 VAC/VDC maximum, 1 Amp maximum 100 VA, 240 VAC/VDC maximum, 3 Amp maximum 42 va @ 28 VDC relay rating 5 amp @ 120 VAC relay rating
Enclosure Rating	NEMA 4 (OZ Gedney); NEMA 4,7,9 (Pyromation); NEMA 4X IP66 (Moore) Class I, Div. 1, Groups C & D
Enclosure Material	316/316L stainless steel or cast iron/aluminum or all aluminum
Electrical Connection	½" NPT or conduit box(es) with ¾" NPT

3.5.3 Dimensional Specifications – inches (mm)

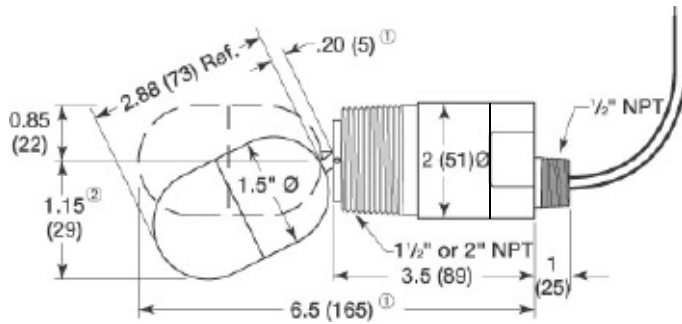

L070 with threaded connection and SPST or SPDT switch with flying leads

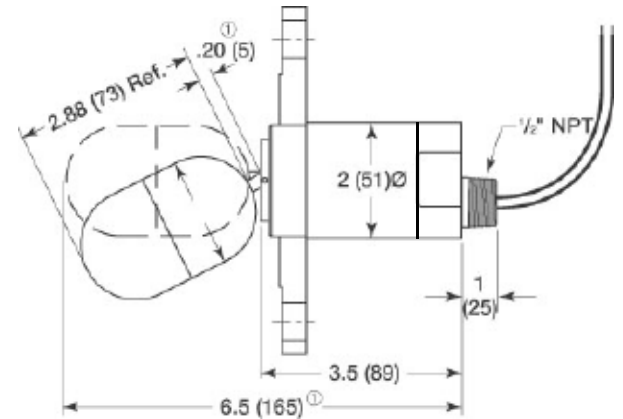

L070 with flanged connection and SPST or SPDT switch with flying leads

- ① Add 0.75" for models with extended stems.
- ② Travel below center line is 1.44" (37 mm) for models with extended stems.

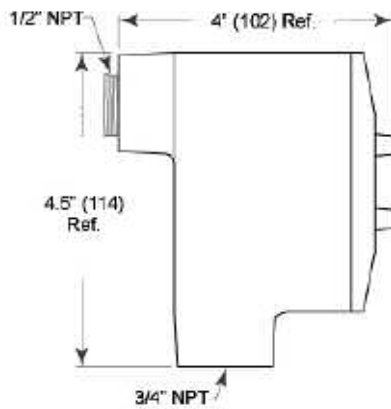

Junction box supplied with DPDT relay

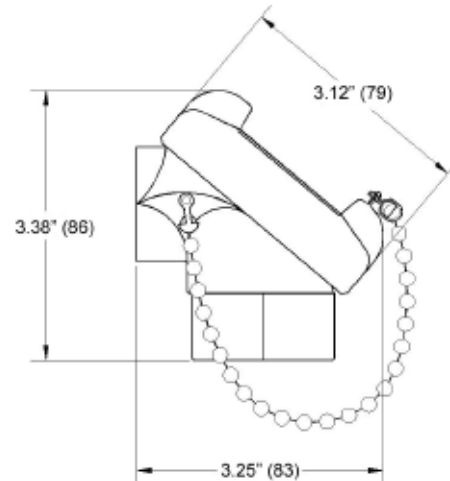

Junction box available with SPST or SPDT reed switch

Nozzle Limits – Inches (mm)

	Maximum Allowable Nozzle Lengths		Minimum Nozzle ID Required for Longer Length
	1 1/2" NPT ^①	2" NPT ^②	
Standard Stem	0.71 (18)	1.94 (49)	2.30 (58)
Extended Stem	1.25 (32)	n/a	2.88 (73)

- ① Based upon nozzle ID equaling 1.70 (43).
- ② Based upon nozzle ID equaling 2.17 (55).

3.6 Model Numbers

TECHNOLOGY TYPE

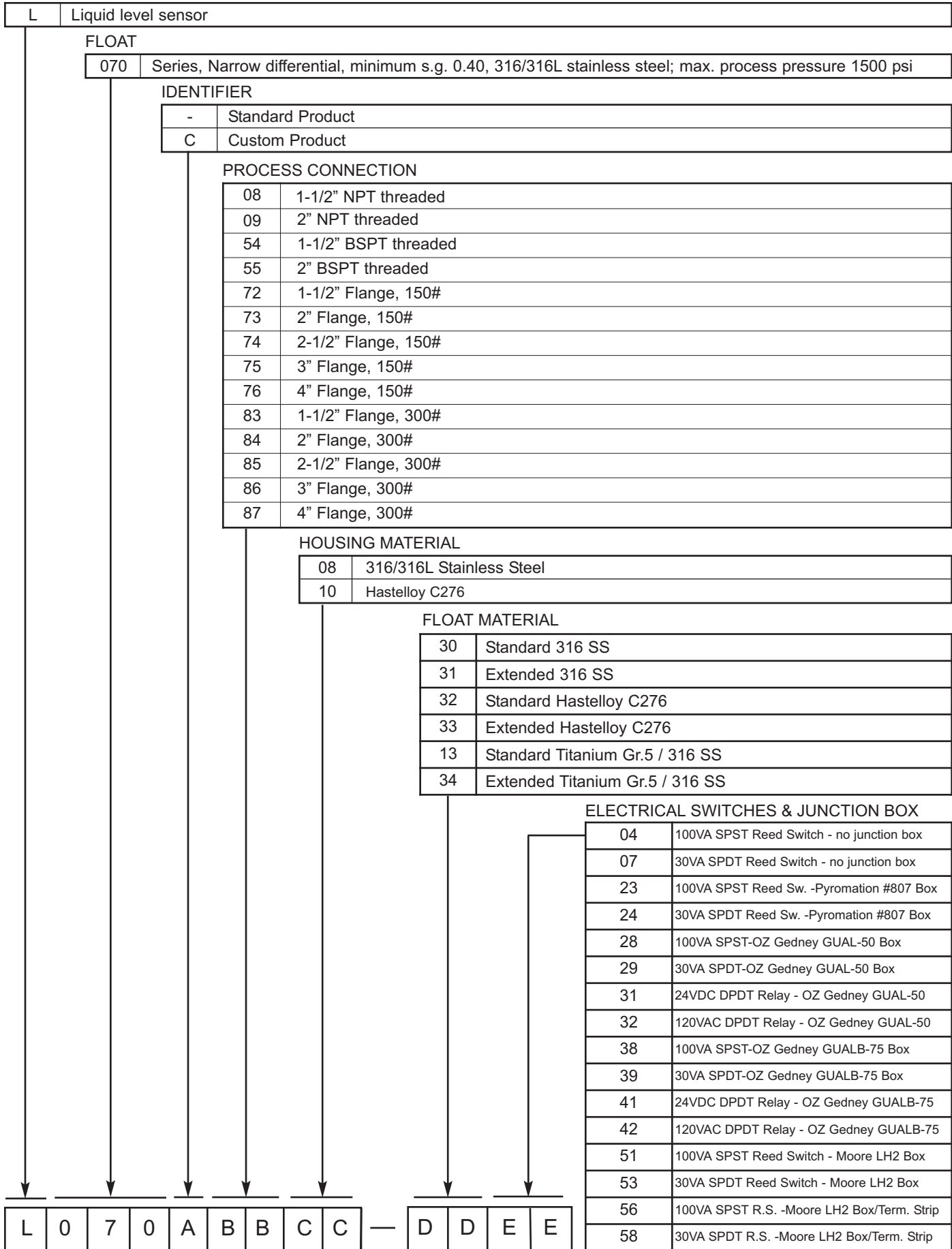

Notes

Service Policy

Owners of Innovative Solutions controls may request the return of a control or any part of a control for complete rebuilding or replacement. They will be rebuilt or replaced promptly. Controls returned under our service policy must be returned by Prepaid transportation. Innovative Solutions will repair or replace the control at no cost to the purchaser (or owner) other than transportation if:

1. Returned within the warranty period; and
2. The factory inspection finds the cause of the claim to be covered under the warranty.

If the trouble is the result of conditions beyond our control; or, is NOT covered by the warranty, there will be charges for labor and the parts required to rebuild or replace the equipment.

In some cases it may be expedient to ship replacement parts; or, in extreme cases a complete new control, to replace the original equipment before it is returned. If this is desired, notify the factory of both the model and serial numbers of the control to be replaced. In such cases, credit for the materials returned will be determined on the basis of the applicability of our warranty.

No claims for misapplication, labor, direct or consequential damage will be allowed.

Return Material Procedure

So that we may efficiently process any materials that are returned, it is essential that a "Return Material Authorization" (RMA) number be obtained from the factory, prior to the material's return. This is available through Innovative Solutions local representative or by contacting the factory. Please supply the following information:

1. Company Name
2. Description of Material
3. Serial Number
4. Reason for Return
5. Application

Any unit that was used in a process must be properly cleaned in accordance with OSHA standards, before it is returned to the factory.

A Material Safety Data Sheet (MSDS) must accompany material that was used in any media.

All shipments returned to the factory must be by prepaid transportation.

All replacements will be shipped F.O.B. factory.

