



**L500E**

**Description**

The wider displacement L500E multi-level switch for hazardous locations monitors up to eight independent levels in a single device. Available in lengths to 15 feet, these sensors are constructed in all 316 stainless steel with a variety of enclosures, mounts, and other options.

With only a single entry, the L500E can track changing levels within the tank as well as monitoring liquid interfaces of dissimilar liquids in a single tank like oil/water separations, chemical emulsions, or condensate levels.

**Principle of Operation**

A hermetically sealed reed switch is actuated by a magnet inside the float. As the float rises and falls, the magnetic field passing the switches within the stem causes the switches to either close or open.

**Product Configuration Choices**

- Mounting & Materials: Select mounting size, mount and stem material, float material, switch type, and optional enclosure from Table A.
- Float Size: Select float from Table B.
- Switch Wiring: Select switch wiring from Table C.
- Actuation Levels: Select switch actuation level from Section D.

**Approvals**

- UL (Underwriters Laboratories) Recognized
- CUL (Canadian UL0 Recognized)
- FM (Factory Mutual) Class I, Div 1, Groups A, B, C, & D

Class II, Groups E, F, & G

Class III, T4



**A. Component Choices L500E**

Series	Mounting Types		Mounting & Stem Materials		Float Materials		Switch Type		Enclosures	
L500E	09	2" NPT	08	316/316L SS	08	316 Stainless Steel	55	50VA SPST w/terminal	00	No enclosure
	10	3" NPT	10	Hastelloy*			56	100VA SPST w/terminal	01	Aluminum, ½" NPT
	11	4" NPT					57	30VA SPDT w/terminal	02	Small Cast ¾" NPT
	64	2½" Sanitary Flange								
	73	2" 150# ANSI Flange							03	Large Cast ½" NPT
	74	2½" 150# ANSI Flange								
	75	3" 150# ANSI Flange								
	86	3" 300# ANSI Flange								



Example: L500E-0908-0855-01 = 2" NPT mounting; 316SS mounting & stem material; 316 SS float; 50VA SPST switches; aluminum enclosure

\*Other mountings and materials are available. Consult factory for details.

Bulletin: IS-191.0  
Effective: December 2009

**B. Float Sizes and Operating Specifications**

Float Materials	Dimensions	Available Mount Types	Temperature	Pressure	Minimum Specific Gravity
316 stainless steel	2" Ball	All	-40° to +300° F	750 psig	.75
	2.5" Ball			200 psig	.60
	3.5" Ball			300 psig	.40
	1.5" x 1.3" Cylinder			120 psig	.80
	2" Diameter Oblong			300 psig	.80

**C. Switch Wiring and Electrical Specifications**

- Each switching point requires one float. For special applications, a single float can be used to activate two switch points, though these points must have a minimum separation of ½" (12mm). The maximum number of actuation levels depends on the wiring type selected.
- Ratings: 50, or 100 VA @ 240 VAC SPST  
100 W @ 240 VAC SPDT
- Connection: Terminal Strip #22 AWG
- Mounting Attitude: Vertical ±30°



**Group 1 SPST  
One Common Wire**

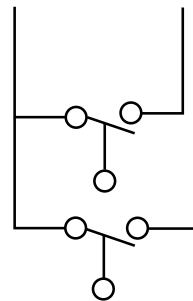

**Group 2 SPST  
Independent Circuits**

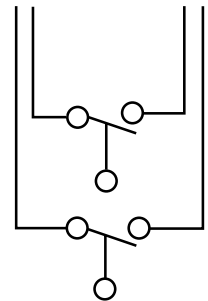

**Group 3 SPDT  
One Common Wire**

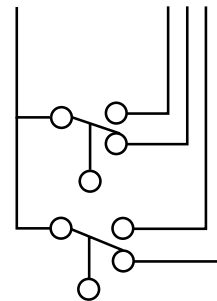

**Group 4 SPDT  
Independent Circuits**

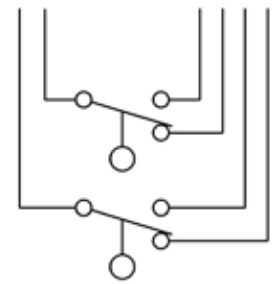

**C. Switch Wiring and Electrical Specifications**

Wiring Options	Group 1 SPST	Group 2 SPST		Group 3 SPDT		Group 4 SPDT		
Common Wire	Black	None		Black		None		
	NO/NC	NO or NC		NO	NC	Common	No	NC
L1	Red	Red	Red	Red	White-Red	Red	White-Red	White-Black-Red
L2	Yellow	Yellow	Yellow	Yellow	White-Yellow	Yellow	White-Yellow	White-Black-Yellow
L3	Blue	Blue	Blue	Blue	White-Blue			
L4	Brown	Brown	Brown					
L5	Orange							
L6	Gray							

Bulletin: IS-191.0  
Effective: December 2009

**D. Actuation Level Dimensions**

- A = 1½" (38mm) minimum distance from actuation point to inside surface of tank or mounting pad.
- B = 3" (76mm) minimum distance between actuation levels.
- C = 2" (51mm) minimum distance from end of unit to lowest actuation level.
- D = ½" (12mm) minimum distance between points when a single float is used to activate two switches. (One float can activate two switches when the lower switch is NC and the upper switch is NO.)

**Notes**

1. A, B, and C dimensions are based on a specific gravity of 1.0.
2. When using one float for two actuation positions, contact the factory for available switch ratings.
3. Actuation levels are calibrated on descending fluid level, with water as the fluid, unless otherwise specified.
4. Standard tolerance on actuation levels is ±1/8" (3mm).

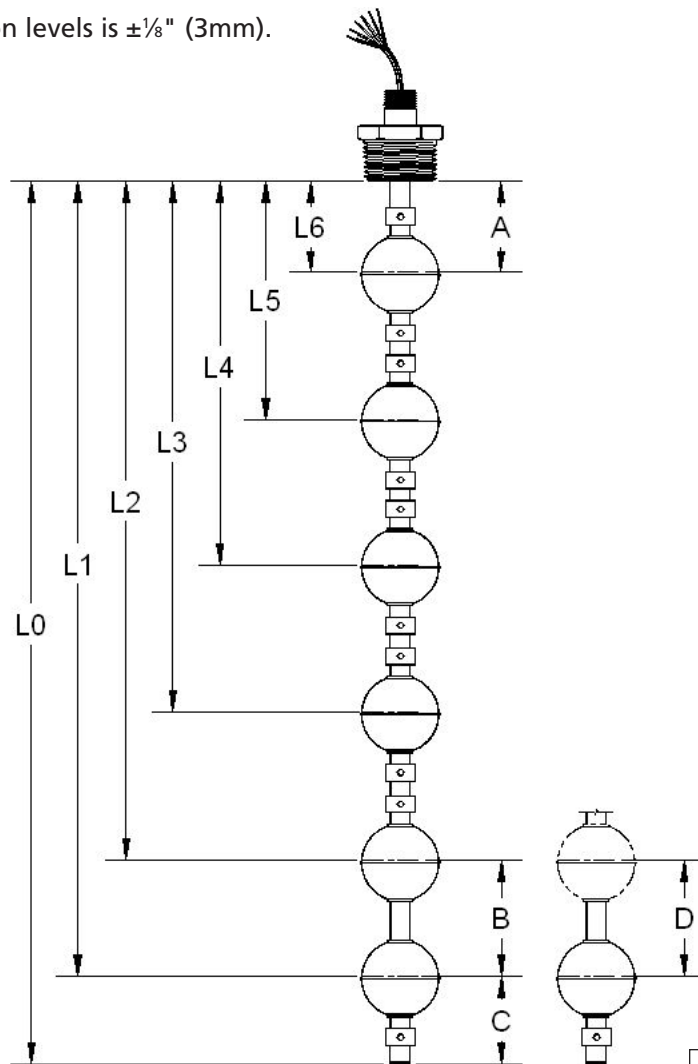

Bulletin: IS-191.0  
 Effective: December 2009